

AERZEN
SCREW COMPRESSORS

Aerzen VMX Screw Compressor Unit equipped with oil injection
specially designed for incorporation into stationary and mobile
air compressor plants



AERZENER MASCHINENFABRIK
GMBH

V1-020 06 EN
2000 3.2003

General

Aerzener VMX-screw compressors with oil injection are designed for intake flow volumes from 70 up to 3180 m³/h at driving speeds of 50 resp. 60 Hz and an overpressure - single-stage - up to 13 bar (higher pressures or admission pressure operation upon request). At vacuum operation - single-stage - intake pressures up to 0,1 bar abs. are obtained. The drive is effected via V-belt resp. toothed belt or directly via a flexible coupling from the driving motor to the male rotor of the air end.

Drive by electric motors or internal combustion engines.

All stages are suitable for frequency converter-operation (standard).

Possibilities of application

VMX screw compressors are supplied as components to manufacturers of mobile and of stationary air compressor plants who make themselves the accessories or plant components- as oil coolers, oil separators, base frames, etc.- and carry out the final completion of the whole plant unit.

Construction

type	equipped with oil-injection
bearings	roller bearings
lubrication	forced oil lubrication
housing	air cooled
lubric. oil	air cooled or water cooled
materials	housing GG 20 rotors C 45 N
drive	V-belt, toothed belt or direct coupling with the driving motor (frequency converter-operation)
sealing of driving shaft	journal type sealing ring

Advantages of screw compressors equipped with oil-injection

- high operational reliability
- long working life
- low maintenance costs
- excellent efficiency
- Few wearing parts, no inlet or exhaust valves requiring maintenance.
- Rotors work in a non-contact way, without the timing gears otherwise usual.
- Injected oil ensures adequate lubrication and cooling, and provides the sealing between the rotors themselves and between these and the walls of the housing. All this offers the best possible guarantee for the highest efficiency.

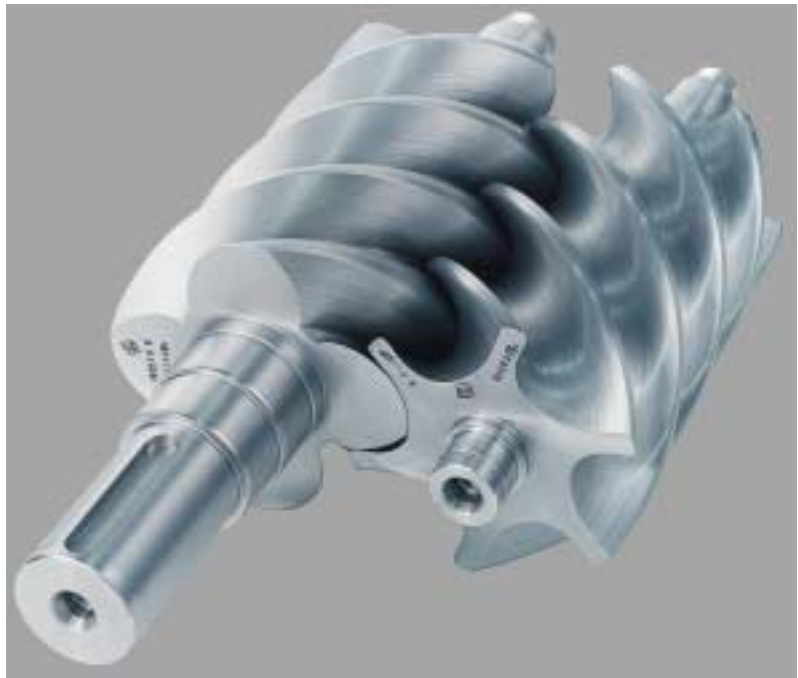

- Vibration free
- low noise level
- small overall dimensions
- low weight.
- No reciprocating parts, rotary movements only, all rotating parts dynamically balanced, no special foundations required, easy to install within the confines of the compressor plant unit.
- All stages suitable for frequency converter-operation.

Mode of operation

The VMX screw compressors are twinshafed rotary piston machines of positive displacement design, operating with internal compression. The air handled is compressed on its way from the intake socket (situated on top of the housing) to the discharge socket (located at the bottom of the housing) in ever diminishing chambers, finally being discharged into the discharge pipe.

During the compression process oil is injected into the conveyance chambers. The injected oil fulfils the following functions during this operation: lubrication of bearings and rotors, sealing of the clearances between the rotors themselves, and between these and the cylinder walls, conducting away the heat generated compression process, reducing sound.

The oil must subsequently be extracted from the air by means of an oil separator installed after the compressor, it is then cooled.

The bearings and the rotors are lubricated via injection passages of optimum dimensions, at an oil pressure that depends on the discharge pressure; this eliminates need for an oil pump. The quantity of oil injected is controlled by the temperature in such a way as to ensure that the final compression temperature will adjust itself to about 85 °C.

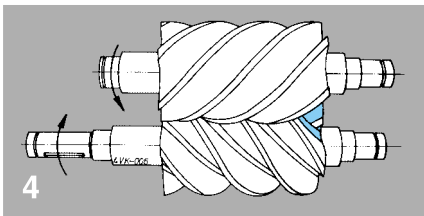
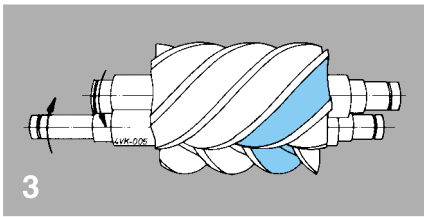
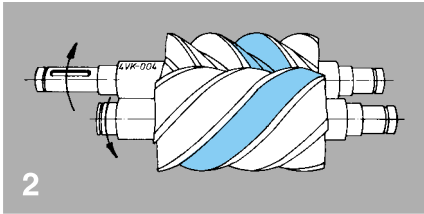
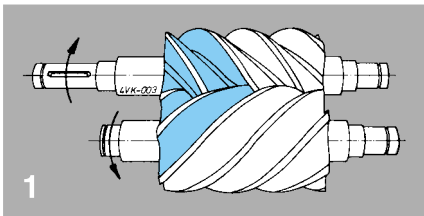

- 1 **Intake**
Air enters through the air intake aperture and flows into the helical grooves of the rotors which are open at the intake side.
- 2 and 3 **Compression process**
As rotation of the rotors proceeds, the air intake aperture closes, oil is injected, the volume diminishes and pressure rises.
- 4 **Discharge**
The compression process is completed, the final pressure attained, the discharge commences.

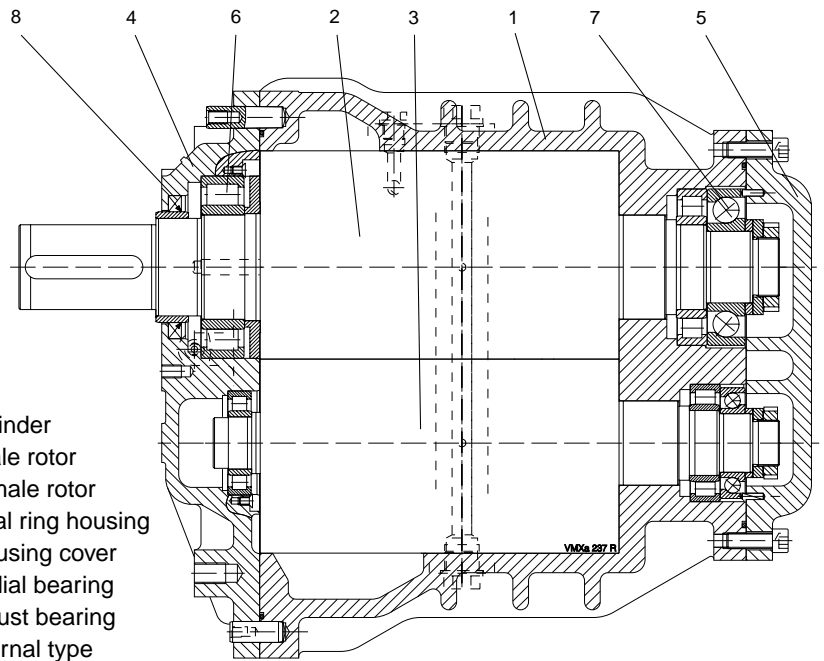

- 1 cylinder
- 2 male rotor
- 3 female rotor
- 4 seal ring housing
- 5 housing cover
- 6 radial bearing
- 7 thrust bearing
- 8 journal type sealing ring

Performance data: intake pressure $p_1 = 1$ bar, intake temperature $t_1 = 20$ °C

VMX size	Q_1 (m ³ /min) min - max	** P (kW) min - max	admissible pressure range
VMXa 0937 R	1,15 - 3,5	15,0 - 22,0	from 4 to 13 bar overpressure
VMXa 037 R	2,5 - 6,8	15,0 - 45,0	
VMXa 137 R	4,5 - 11,0	30,0 - 75,0	
VMXa 237 R	7,5 - 17,5	55,0 - 110,0	higher pressures or admission pressure operation upon request
VMXa 337 R	11,5 - 28,3	75,0 - 160,0	
VMXa 437 R * belt drive	18,0 - 42,0	132,0 - 250,0	
VMXa 437 R * frequency converter operation	18,0 - 53,0	132,0 - 355,0	

* in preparation

** compressor shaft capacity



Dimensions, design VMXa...R

Dimensions without engagement

type	A	B	C	D	E	F	G	H	J	L	M	O	P	Q	R	S ₁	S ₂	T	V	W	Y ₁	Y ₂	Y ₃
VMXa 0937 R	333	172	65	244	144	134	25	85	85	77	68	∅ 70	∅ 40	33,5	135	164	-	125	M12	M10	185	62	G ¹ / ₂
VMXa 037 R	389	194	110	301	170	163	30	100	100	88	85	∅ 80	∅ 50	25	135	-	120	144	M12	M12	223	73	G ¹ / ₂

type	a	a ₁	b	b ₂	c	d	e	f	g	h	j	k	l ₁	l ₂	m	n	o	p	q	r	s	t ₁	t ₂	u	weight GG-25
VMXa 0937 R	□110	M10	□80	M10	∅ 106	∅ 80	67	68	37	237	53	92	45	-	41	38	10	5	52	45	G ¹ / ₄	G ³ / ₈	-	G ¹ / ₄	28,5 kg
VMXa 037 R	□120	M12	□80	M12	∅ 135	∅ 80	65	82	45	188	63	117,5	-	53	45	42	12	3	60	56	G ¹ / ₄	-	G ³ / ₈	G ¹ / ₄	48,5 kg

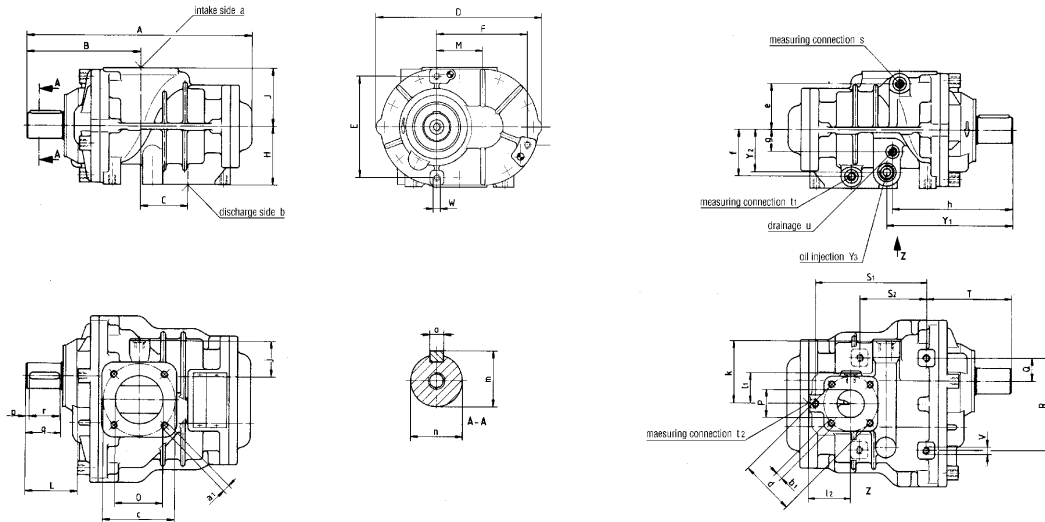

Dimensions, design VMXa...R

Dimensions without engagement

type	A	B	C	D	E	F	G	H	J	L	M	N	O	P	Q	R	S	T	V	W	X ₁	X ₂	X ₃	Y ₁	Y ₂	Y ₃
VMXa 137 R	479	234	141	380	210	186	95	135	135	109	106	-	∅ 100	∅ 55	61	227	188	177	M16	M16	51	100	G ¹ / ₈	277	87	G ³ / ₄
VMXa 237 R	608	325	150	435	234	235	90	160	160	135	135	310	∅ 150	∅ 80	-	-	240	260	-	M16	63	120	G ¹ / ₈	340	110	G ³ / ₄
VMXa 337 R	760	405	180	598	320	298	92	250	240	165	168	480	∅ 180	∅ 100	101	370	350	303	∅ 23	M20	70	155	G ¹ / ₈	395	135	G 1

type	a ₁	a ₂	b ₁	b ₂	c	d	e	f	g	h	j	k	l	m	n	o	p	q	r	s	t ₁	t ₂	u	weight GG-25
VMXa 137 R	□150	4xM16	-	4xM16	∅ 160	∅ 125	95	100	48	272	80	120	-	59	55	16	5	80	63	G ¹ / ₄	-	G ³ / ₈	G ¹ / ₄	118 kg
VMXa 237 R	∅ 260	8xM16	□160	4xM16	∅ 225	∅ 160	125	120	65	288	90	150	-	69	65	18	5	105	90	G ³ / ₈	-	G ³ / ₈	G ³ / ₈	207 kg
VMXa 337 R	∅ 340	12xM20	∅ 220	8xM16	∅ 295	∅ 180	210	150	97	450	96	250	-	85	80	22	5	130	120	G ³ / ₈	-	G ³ / ₈	G ³ / ₈	470 kg

Size VMXa 437 R in preparation

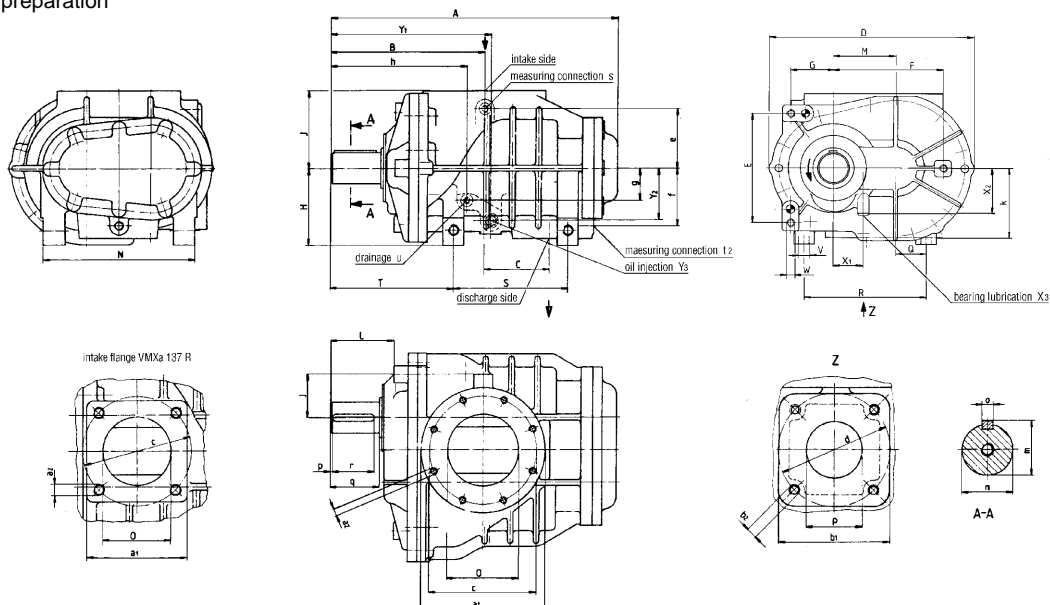

Aerzener Maschinenfabrik GmbH

Reherweg 28 · 31855 Aerzen / Germany - P.O.Box 1163 · 31849 Aerzen / Germany

Phone ++4951 54/8 10 · Fax ++4951 54/8 11 91 · <http://www.aerzener.com> · E-mail: info@aerzener.de